



# NFBA POST-FRAME FORUM

Your connection to the NFBA and the latest in Post-frame Industry news

## AUGUST 2019 ISSUE

T&R UPDATE

MEMBER HIGHLIGHT

LEGAL UPDATE

## UPCOMING EVENTS

POST FRAME ADVANTAGE ONLINE UNIVERSITY

SAFETY MANUAL TEMPLATE WEBINAR

2020 EXPO DES MOINES FEB 26TH - 28TH

## AFFILIATE EVENTS

CANADIAN FARM BUILDERS ASSOCIATION GOLF TOURNAMENT

HEARTLAND CHAPTER NFBA ANNUAL MEETING AND GOLF SCRAMBLE

## NFBA: CURRENT EVENTS

As summer quickly rolls on, our Board and Committees continue to work on developing NFBA Programs and Services for you, our Members and Associates. Here are just a few highlights that we would like to update you on regarding current projects:

The Industry Promotion Committee (formerly PFMI) is taking a whole new approach to the Post-Frame Advantage Initiative. This program generates funds to support the use and development of Post-frame Construction. Expect to see communications in your inbox and in your mailbox about where the initiative is headed and how it will benefit the Industry and your business!



The Marketing Steering Committee is engaged in the development of a new NFBA Publication. This publication will be sent to all NFBA Members and Associates digitally. NFBA Members will automatically receive a printed copy of the publication as well! Watch for it this September. The Committee has also worked to develop the new NFBA website, and will be launching a new look for our existing programs and services.



The NFBA Board has brought on a new management team to ensure the continued development of existing programs, and to allow for a fresh look at generating new programs and services. NFBA's top priority is always to bring their Members, Affiliates, Expo and Program Attendees the largest return possible on their investment.

Executive Director, Megan Miller

[mmiller@nfba.org](mailto:mmiller@nfba.org)

Membership Director, Morgan Arwood

[marwood@nfba.org](mailto:marwood@nfba.org)

Managing and Expo Director, Rachel Pinkus

[rpinkus@nfba.org](mailto:rpinkus@nfba.org)

Managing and Curriculum Director: Bob Pope

[bpope@nfba.org](mailto:bpope@nfba.org)

Local: 937-999-5044

Fax: 937-278-0317

*No changes will be made to our website, general email, and toll free number:*

[www.nfba.org](http://www.nfba.org) - [info@nfba.org](mailto:info@nfba.org) - 800-557-6957

# CHAPTER EVENTS

## **CFBA Annual Golf Tournament:**

Craigowan Golf Club

Wednesday, September 18, 2019

Register now for for the **CFBA's Annual Golf Tournament** to be held on **Wednesday September 18th** at **Craigowan Golf Club**, just north of Woodstock. Your colleagues, clients, and suppliers will thank you for inviting them to this event! You are eligible for the Early Bird prize draw if you register by August 31st. Please click the following link for Registration details: [http://www.cfba.ca/cfba\\_golftournament/](http://www.cfba.ca/cfba_golftournament/)

Please let us know if you are able to support us with a sponsorship: Golf Prizes (\$75, \$150, \$250), Golf Hole (\$200), Straightest Drive(\$200 + prize), and Appetizers - Nacho Bar (\$500).



Canadian Farm Builders Association  
[cfba@cfba.ca](mailto:cfba@cfba.ca) [www.cfba.ca](http://www.cfba.ca)



## **Heartland Chapter NFBA Annual Meeting and Golf Scramble:**

Lake of the Ozarks - Tan-Tar-a Resort

Wednesday, October 2, 2019

Register now for the Heartland Chapter's Annual Meeting and Golf Scramble!

Golf Scramble Tee Off: 11:00 AM  
Dinner Reception/Meeting: 5:00 PM

Please click the following link for Registration and Sponsorship details:  
<https://heartlandnfba.org/annual-meeting>

Book your room now at the Tan-Tar-a Resort. Ask for the Heartland Chapter Rate when booking. Deadline for special rate is September 4th! For room reservations call 800-826-8272 or visit [www.tan-tar-a.com](http://www.tan-tar-a.com)

Visit the Heartland Chapter website at: <https://heartlandnfba.org/>

## HEARTLAND CHAPTER

---

## NFBA

NATIONAL FRAME  
BUILDING ASSOCIATION

# TECHNICAL AND RESEARCH UPDATE

## National Frame Building Association Technical & Research Committee

Timothy R. Royer, P.E., Chairman

### Non-Diaphragm Post Frame Building Design Guide Overview

Recently the National Frame Building Association (NFBA) published the Non-Diaphragm Post-Frame Building Design Guide. The NFBA's Post Frame Building Design Manual (PFBDM) has long been an excellent source of information for the design of post frame buildings, however there was a need to provide a more in-depth explanation of the non-diaphragm design approach. The non-diaphragm



design method is used when diaphragm design is not possible due to the building's lack of shear walls or large length-to-width ratio which create ineffective diaphragms. The Non-Diaphragm Post Frame Building Design Guide not only provides the step by step analysis procedure, it also then gives users two actual building example projects that use the non-diaphragm design method. The following is a sample of the information conveyed in this valuable design guide.

#### Diaphragm vs. Non-Diaphragm

Most post-frame buildings utilize a roof diaphragm and shear walls (sidewalls and endwalls) to resist lateral wind and seismic loads. The roof diaphragm functions as a horizontal medium through which lateral forces are collected and redistributed to each participating vertical element (wood frame, shear walls). Buildings that have primary wood frames with no lateral rigidity (columns simply supported at top and bottom) depend entirely on the diaphragm-shear-wall system for lateral load resistance and stability. Buildings with very stiff primary frames and relatively flexible diaphragms are less dependent on the diaphragm-shear-wall system. Post-frame buildings that lack shear walls, or buildings with a large length-to-width ratio, and therefore ineffective diaphragms, resist lateral loads wholly within the primary wood frames and are classified here as **non-diaphragm buildings** (Figure 1).

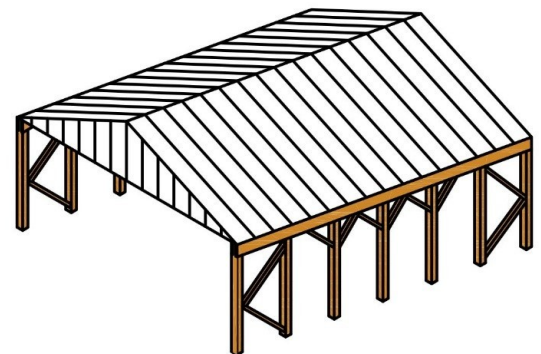

**Figure 1:** Open *non-diaphragm* building

#### Lateral Loading

Minimum design loads on buildings are governed by the ASCE Standard ANSI/ASCE 7-16 Minimum Design Loads for Buildings and Other Structures (Figure 2). As of this writing, ASCE 7-16 is the most current edition, and the requirements defined in that document are referenced throughout this guide. A more in-depth discussion on this topic is available in the NFBA Post-Frame Building Design Manual (PFBDM) (2015), Chapter 3. Wind loads on buildings and building components are calculated in accordance with ASCE/SEI 7-16 using either the directional procedure (ASCE/SEI 7-16, Chapter 27) or the envelope procedure (ASCE/SEI 7-16, Chapter 28). Wind pressures on main wind force resisting system (MWFRS) and on components and cladding (C&C, ASCE/SEI 7-16, Chapter 30) are calculated separately.

(Continued next page)

# TECHNICAL AND RESEARCH UPDATE CONTINUED

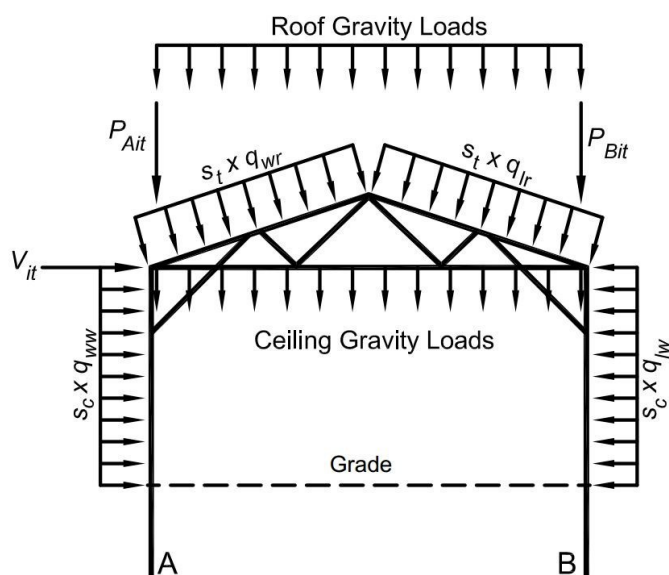

**Figure 2: Loading on Structural Model**

When determining the worst wind effect on the lateral force resisting system (LFRS) perpendicular to ridge, the total horizontal shear on the building shall not be less than that determined by neglecting wind forces on the roof. The total horizontal shear shall not be less than 16 lbf/ft<sup>2</sup> multiplied by the wall area and 8 lbf/ft<sup>2</sup> multiplied by the roof area projected onto a vertical plane normal to the assumed wind direction (Figure 2).

Post-frame building systems and components must meet deflection limits specified in the governing code. The building designer should also consider deflection requirements related to door/window operations, clearances, and aesthetics depending on the function of the building. The deflections are calculated using service loads (non-factored loads).

## Structural Analysis

The lateral load analysis of non-diaphragm buildings is arguably simpler than one with a functioning structural diaphragm. Analysis of buildings with diaphragms must consider individual stiffness of primary frames, foundation, roof diaphragm, endwall bare-frame, and endwall sheathing to determine what effect each participant has on the overall building before loads can be properly distributed. In contrast, the non-diaphragm analysis is mostly limited to the primary wood frame consisting of posts and a truss. The lateral force resisting system (LFRS) provides lateral stability and resistance to horizontal loads on a building. LFRS must be designed for loading in the direction perpendicular to the ridge and parallel to the ridge (Figure 4). Chapter 4 of the Non-Diaphragm Post Frame Building Design Guide provides procedures for designing LFRS in each direction.

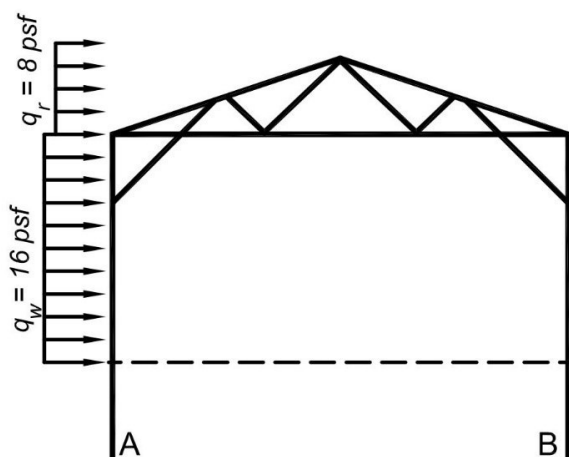

**Figure 3: Minimum design wind speed loads perpendicular to the ridge**

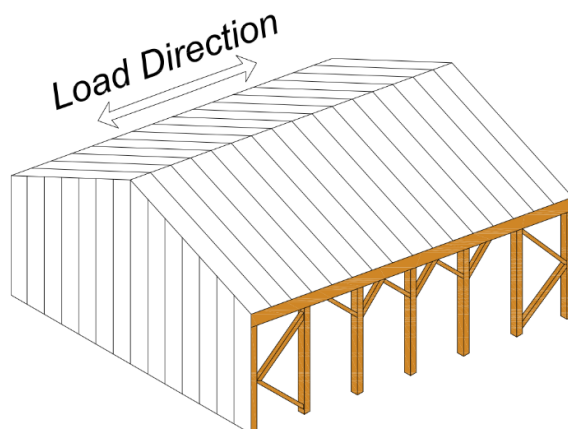

**Figure 4: Common LFRS vertical elements (braced frame, columns with wye braces) Parallel to the ridge.**

(Continued next page)

# TECHNICAL AND RESEARCH UPDATE CONTINUED

## Design of Members

The purpose of this chapter is to provide an overview of the structural design process for the primary and secondary framing members in a non-diaphragm post-frame building. More emphasis is given to the subject of columns and knee braces because these components comprise approximately two thirds of the lateral force resisting system that is critical for the lateral stability in any non-diaphragm post-frame building. A primary frame truss is also an integral part of the lateral force resisting system; however, the design of the trusses is typically the responsibility of the truss manufacturer and is outside the scope of this guide. The design considerations for other primary and secondary members are covered in detail in the NFBA PFBDM (2015), Chapters 4 through 8.

## Knee Brace Design

Knee braces are designed to resist axial compression and axial tension forces and are governed by the NDS-2015 (Figure 5). The load distribution from the knee brace into the top and bottom chords of truss is dependent on truss member sizes and configuration. Trusses in non-diaphragm buildings are designed for additional concentrated point loads from the knee braces applied to the top and bottom chords of truss. It is the responsibility of the building designer to clearly communicate knee brace reactions for every applicable service load and to ensure that the truss designer understands and correctly applies these forces to the truss.

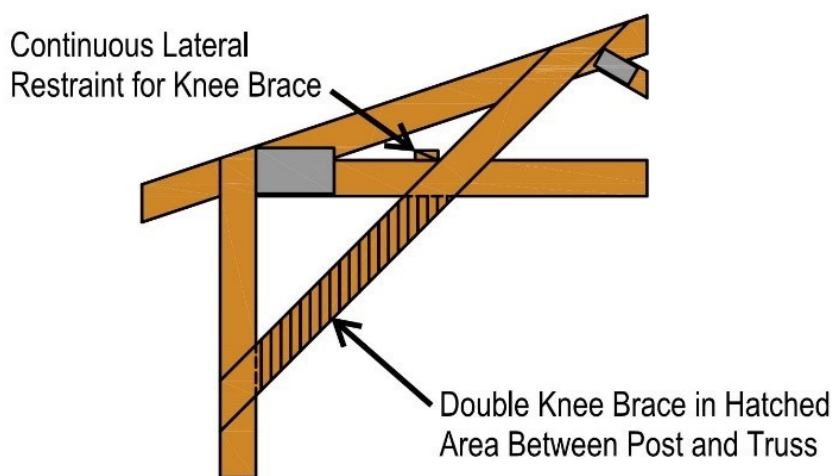

**Figure 5:** Reinforcement of the knee brace segment between bottom chord and post.

## Other Considerations

Chapters six through nine of the Non-Diaphragm Post Frame Building Design Guide presents connection design, foundation design, cladding requirements and other considerations. One of the other considerations is mechanically laminated column design for open sided buildings. The ASABE EP559.1 (R2014) standard has two limitations that negatively affect open post-frame buildings:

(Continued next page)

## TECHNICAL AND RESEARCH UPDATE CONTINUED

1. Posts must have sufficient lateral bracing perpendicular to laminations to prevent buckling about the weak axis (axis parallel to wide face of laminations).
2. Posts may have bending only about the strong axis; EP559.1 (R2014) does not have provisions for column design with bending forces about the weak axis. It follows that posts designed in accordance with EP559.1 (R2014) may not be used in most open buildings (walls with no lateral bracing) and are not suitable for applications with wye braces where loading about the weak axis is expected

**Example design projects** Design examples are given in chapters 10 through 14 for two building projects. Each project is designed in allowable stress design (ASD) and load and resistance factored design (LRFD). The two example projects are a 50ft x 80ft x 10ft open building (Figure 6) and a 50ft x 80ft x 14ft with one gable end wall open (Figure 7). The first building has embedded columns and the second has columns bearing on a concrete foundation wall. The sample calculations are detailed and reference many other engineering standards that apply to post frame building design.

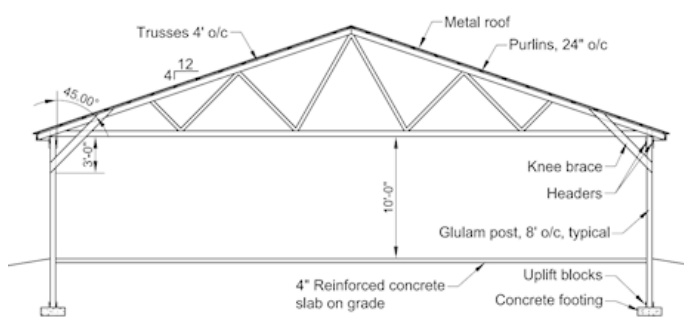

**Figure 6:** Design Example 1 - Typical section through the building

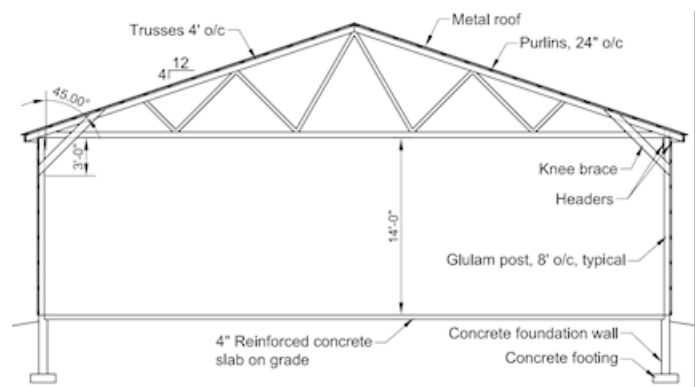

**Figure 7:** Design Example 2 - Typical section through the building

Hopefully this article has sparked your interest in the design of non-diaphragm post frame buildings. In March of 2019 the Non-Diaphragm Post Frame Building Design Guide was made available from the National Frame Builders Association website in digital and hardcopy form. This is a valuable tool and reference that all post frame designers should have in their bookcase.



***Save the Date!***

**NFBA Frame Building Expo**

**February 26-28, 2020**

**Iowa Events Center - Des Moines, IA**

The Annual NFBA Frame Building Expo is the premier event for post-frame professionals. At the Frame Building Expo, everything you need to build your post-frame business is assembled under one roof. From an expansive list of exhibitors ready to demonstrate the newest innovations to educational sessions led by deeply invested presenters and industry leaders, you can expect to make all of the connections necessary to make smarter business decisions, grow your bottom line and enhance credibility for your business.

***Registration opens Fall 2019***

# NFBA MEMBER HIGHLIGHT: GREINER BUILDINGS

We are endeavoring to highlight NFBA Members in each issue of our newsletter and magazine. To kick things off, this issue's Member Highlight features our current Chair, Matt Greiner, President of Greiner Buildings.

Matt was born in a small town in Washington, IA where he currently resides with his wife Ashley and daughter Brooklyn. Washington, a town of just under 8,000 people, is where his company Greiner Buildings, Inc. is headquartered.



He and his business partner, Shawn Redlinger, met at just 6 or 7 years old at their Catholic grade school and have been friends ever since. Together they have led the current GB team to where it is today; taking the hard work his Dad, Tom, put into starting the company and building it into its modern day form.

Matt grew up around post frame construction. His dad started his construction company when Matt was very young and started teaching him the craft. He learned to drive a tractor when he was just 5 years old. He started running crews in his mid-teens and ran his own post frame contracting business while attending college.

Safety is a priority in his business and service to NFBA. "I actually fell 17 feet off a machine shed years ago, breaking my nose and wrist. The experience has anchored me to the Safety Committee as a priority for NFBA." Each year, Matt and his employees are sure to attend the NFBA Conference and never miss the Safety Education. "It's really sparked a culture change within our company Greiner Buildings has partnered with NFBA, Lester Buildings, and FBI Buildings to study and investigate current safety



equipment options. The goal is to develop better and safer methods of fall protection specific to the post-frame industry.

Family means the world to Matt. He loves spending time with Ashley and Brooklyn either riding bikes, playing games, landscaping, or just hanging out watching TV. Matt also enjoys traveling. "I have enjoyed my travels with the NFBA."

(Continued next page)



## NFBA MEMBER HIGHLIGHT CONTINUED



“Fueling my inner-child,” for Matt, consists of racing and music. After relentlessly racing cars for 15 years, bringing home 13 Track Championships, over 100 victories, and a couple great showings in the National Championships, Matt discovered his passion for music. Matt now plays lead guitar in several bands. Additional hobbies include weight-lifting, riding bikes, basketball, and watching sports (particularly the Iowa Hawkeyes-his alma mater!)

NFBA Conference brought him to his favorite place in the world—Nashville. He loves to go on the strip and enjoy the live music. Last time there, he played a few songs on stage with one of the bands. Other places he’s been able to visit include Tampa, Palm Springs, and Newport Beach, San Diego (two different cities). Matt’s team looks forward to conference each year. His employees consider it to be fun! “It’s a nice working-vacation for everyone, a chance to get away from the daily grind, meet new people and learn new things about post frame construction. We are very blessed to have this opportunity with the NFBA.”



Matt became a CEO at just 23 years old, after graduating with a business degree from the U of Iowa. Along with Greiner Buildings, he also owns Greiner Technology Development. “The main focus of GTD is to be an in-house application. It automates a lot of manual tasks and adds efficiency and accuracy to much of what we do.”

Innovative in his own thinking, Matt’s emphasis on developing a positive work environment includes gifting every new employee a copy of “How to Win Friends and Influence People” by Dale Carnegie, a self-improvement book he encourages them to read, understand, and then practice. “I consider it to be the most influential book ever written”



Greiner Buildings has had a membership with the NFBA since 1999 and has been an NFBA Accredited Builder since 2008. “I believe the networking and connections I’ve made through the association are priceless and have played a role in getting me, my

employees, and company where we are at today where we are today. “

# POST-FRAME ADVANTAGE ONLINE UNIVERSITY



## WEBINAR SCHEDULE:

### **August**

Wednesday, 21 – Universal Method for Shallow Post & Pier Foundation Design

### **September**

Wednesday, 4 – Design Aid for Shallow Post & Pier Foundations

Wednesday, 18 – Intro to Post-Frame Building Systems

### **October**

Wednesday, 16 – 2015 Post-Frame Building Design Manual (2nd Ed)

Wednesday, 30 – Architectural Alternatives for Post-Frame Building Systems

### **November**

Wednesday, 6 – Modern Post-Frame Structural Design Practice: An Introduction

Wednesday, 13 – Diaphragm Design of Post Frame Using Sway & Shear Modifiers– Engineering Details

### **December**

Wednesday, 4 – Diaphragm Design of Post-Frame Using DAFI: Engineering Details

Wednesday, 11 – Simplified Method for Shallow Post and Pier Foundation Design

### **Webinars begin at 1:00 PM Central**

To register for any of these upcoming webinars,

visit the Events section at [www.nfba.org](http://www.nfba.org)

or contact Megan Miller at [mmiller@nfba.org](mailto:mmiller@nfba.org)

*ALL Webinars are approved for 1 hour of continuing education credit, and qualify for AIA Credit.*

## **Fixed Ladder Standard Changes**

By Gary Auman and Kristi Gotwald

Protection from falls is very important for the safety of any business. According to OSHA, “Falls from ladders account for 20 percent of all fatal and lost work-day injuries in general industry.”



(<https://www.osha.gov/Publications/OSHA3903.pdf>.) It is with this in mind that OSHA published new rules in November 2016 regarding fall protection in general industry. The rules involve several aspects of fall protection with varying timeframes for compliance. The first set of rules went into effect in November 2017 regarding training employees, providing equipment, and certifying permanent anchorage points. However, the second set of rules, which involve ladder safety, went into effect just a few months ago in November 2018.

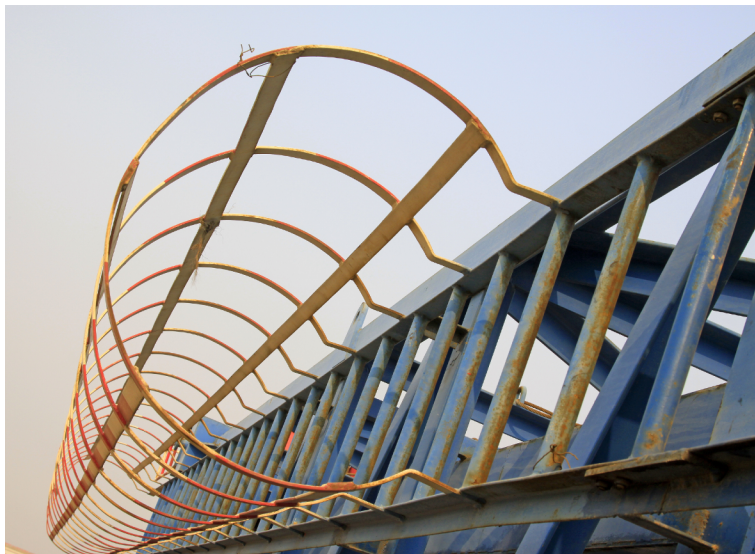

Specifically, the changes affect fixed ladders, not portable ones. Fixed ladders are defined by OSHA as “a ladder with rails or individual rungs that is permanently attached to a structure, building, or equipment.” (29 CFR § 1910.21(b).) Many businesses incorporate the use of fixed ladders in their work. Employers will want to be sure all fixed ladders are made compliant to the new rules or risk OSHA citations, as well as the safety of your employees.

There are really three stages for fixed ladders provided in the changes. If a business currently has a fixed ladder that is over 24 feet, they must now be equipped with a cage, well, personal fall arrest system or ladder safety system. This gives employers options for fall protection on existing fixed ladders. However, if a new fixed ladder over 24 feet has been installed since November 2018 or will be installed in the future, it must have a personal fall arrest or ladder safety system installed in addition to a cage or well. The option on how to provide fall protection to employees is being taken away over time by the new standard. Employers will no longer get to choose, but rather must install personal fall arrest systems or ladder safety systems. Further, if a portion of a fixed ladder must be replaced, or has been replaced since November 2018 the new portion may not

(Continued next page)

## OSHA UPDATE CONTINUED:

depend on a cage or well to satisfy fall protection. Rather, any new portions that are installed, whether as a replacement or an addition, must have a personal fall arrest or a ladder safety system. The final stage for implementation of the new standard for fixed ladders won't become effective for some time. In November 2036 all fixed ladders, no matter when they were installed or whether they have cages or not, must be equipped with a ladder safety or personal fall arrest system if the fixed ladder is over 24 feet. If any cages or wells remain on fixed ladders, they may remain, but they must not interfere with ladder safety or personal fall arrest systems. OSHA is letting industry know that cages and wells are no longer considered adequate to protect workers in the event of a fall.

What qualifies as a ladder safety system? According to an OSHA publication a ladder safety system is "a system attached to a fixed ladder designed to eliminate or reduce the possibility of a worker falling off the ladder. A ladder safety system usually consists of a carrier, safety sleeve, lanyard, connectors, and body harness. Cages and wells are not considered ladder safety systems."  
(<https://www.osha.gov/Publications/OSHA3903.pdf>)



Safety needs to be every employer's top priority. The changes to these rules are intended to reduce fatalities and injuries due to falls when employees use fixed ladders and were made with advances in technology and national consensus standards in mind. Do not forget that you still have an obligation to inspect any fixed ladder before it is used to ensure that it is in good condition and has no defects such as rust or other damage. Remember the OSHA standards change frequently and all employers must be aware how they affect their businesses and the safety of their employees.

***This update was provided by NFBA Legal Counsel,  
Gary Auman, of Auman, Mahan & Furry***

### **NFBA Members please note:**

*The NFBA Legal Services Plan is a Member benefit that you can utilize at any time! This plan provides you the opportunity to get back your investment in dues many times over. Every NFBA Member is entitled to six FREE telephone consultations per year with Gary Auman. His firm specializes in Labor Law, OSHA, and Construction Contract Law. To use this service, Contact Gary Auman at 937-223-6003 or at [gwa@amfd Dayton.com](mailto:gwa@amfd Dayton.com), confirm your current NFBA Membership, and say you are calling under the NFBA Legal Services Plan!*





**REGISTER NOW**  
**Safety Manual Template  
Instructional Webinar**  
**August 27, 2019**  
**2:00 pm CDT/3:00 pm EDT**

Learn more about how your company can effectively use the new NFBA Safety Manual Template

**Click here**  
*or visit the Events section of [www.nfba.org](http://www.nfba.org) to register*

A photograph showing a construction worker on a wooden roof truss structure against a clear blue sky.

**NFBA**  
NATIONAL FRAME BUILDING ASSOCIATION

The NFBA Safety Manual Template is available for purchase to Members only.  
**Click here** to get your digital or printed copy today!

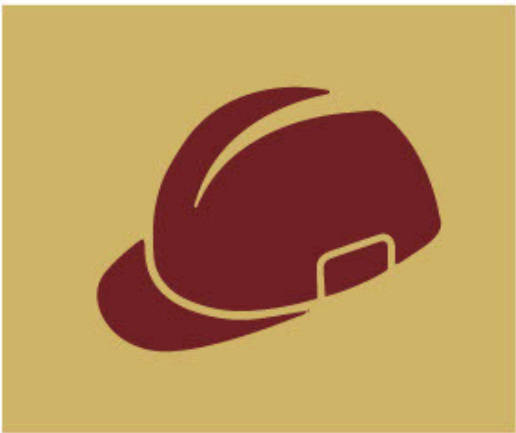
A photograph showing a construction worker in a yellow shirt and hard hat working on a wooden roof truss structure.

**Safety Manual Template**  
A Guideline for the Post-Frame Industry

# Get your message to the NFBA Readership!

*Advertising opportunities are now available for  
the new NFBA magazine coming this fall!*

**CLICK HERE** for details and to select your ad space,  
or contact Rachel Pinkus, Managing Director and Editor



## NFBA Magazine Advertising Rates

B/W Ads	Number of Issues		
	1X	3X	6X
Full Page	\$ 2,900	\$2,755	\$2,617
1/2 Page	\$ 1,800	\$1,710	\$1,625
1/4 Page	\$ 1,050	\$998	\$948

Color Ads	1X	3X	6X
Full Page	\$ 3,800	\$3,610	\$3,430
1/2 Page	\$ 2,700	\$2,565	\$2,437
1/4 Page	\$ 1,900	\$1,805	\$1,715
Back Cover	\$ 4,750	\$4,513	\$4,287
Inside Front <b>SOLD</b>	\$ 4,500	\$4,275	\$4,061
Inside Back	\$ 4,500	\$4,275	\$4,061

For more information about NFBA  
or our publications please contact Megan Miller at:

**NFBA**

2077 Embury Park Rd. Dayton, OH 45414

PH: 800-557-6957 Email: mmiller@nfba.org